

Low-Cost Battery Monitor Checks Battery-Operated Microprocessor

Luke Barker
luke@ljbeng.com
 Deshler, Neb.

A recent project required an inexpensive microprocessor that could be battery operated and indicate if the batteries were low. I chose Microchip's PIC16LF84A for the microprocessor because it was simple to program and could operate between 2.0 and 5.5 V dc.

However, the PIC16LF84A doesn't have analog or comparator inputs. To meet the design criteria for a battery monitor, I went with Microchip's inexpensive MCP100-315 Microcontroller Supervisory Circuit. It costs \$0.33 each in small quantities.

In the circuit, U1 is the PIC16LF84A microprocessor (see the figure). R1 and D1 make up the low-battery indicator circuit. R2 is a 10-k Ω pull-up resistor for the MCLR pin. X1 is a low-power 32.768-kHz oscillator. C1 and C2—68-pF capacitors—were needed so that the oscillator would operate properly.

U2 is the MCP100-315, which actually monitors the battery voltage. The MCP100 is designed to keep a microprocessor in reset until a predefined voltage is present on its VDD pin. The device can operate safely between 1.0 and 5.5 V dc on pin 2, the VDD pin. The RESET pin output of the MCP100 is 0 V if VDD is less than 3.15 V dc, and it will output whatever voltage is on VDD if VDD is greater than 3.15 V. As fresh batteries drain, the microprocessor power supply and RB0 (U1) will always be at the same voltage level, indicating a logic 1 in to the program. Once the battery voltage is less than 3.15 V dc, RB0 (U1) will switch to ground.

The program simply monitors RB0. If there's a logic 0 on that input, the program flashes pin 17 (LED), indicating to the user that the battery voltage is below 3.15 V dc. The datasheet for

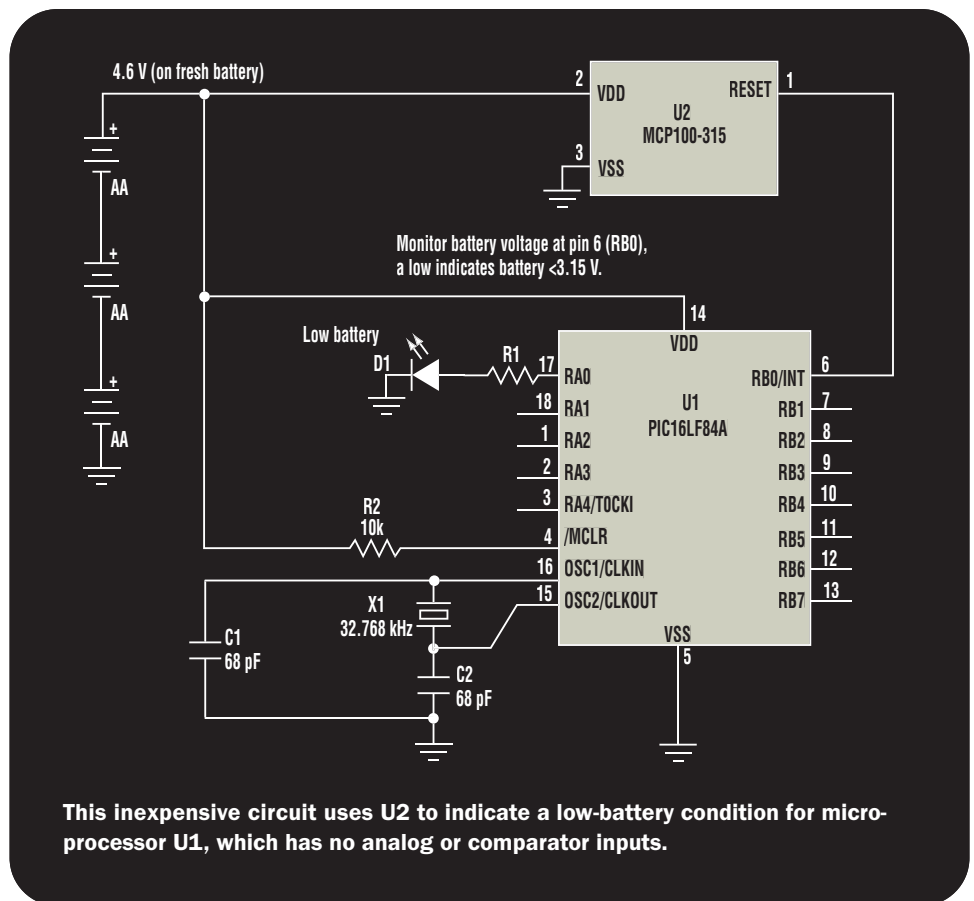

the MCP100-315 indicates that the RESET output will trip at a minimum of 3.0 V dc, typically at 3.075 V dc, and at a maximum of 3.15 V dc.

This circuit presents a simple, inexpensive alternative to monitor battery voltage for any microprocessor-based project. The code for this application can be downloaded from the online version of this article at www.elecdesign.com. **ED**

ED Online 11609

LUKE BARKER, electrical engineer, received a BSEE from the University of Nebraska, Lincoln.